

## LOXrail® floor sleeve with monitoring sensor

Art. No. 480209

Drawing No. 17040-0350

### LOXrail® floor sleeve for 30mm diameter bolt with inductive proximity switch



- For fixation of trolleys at fix positions
- Spring loaded lid seals the sleeve when not in use
- Fixation of trolleys can be monitored by a sensor

- **Deadweight:** 3,12 kg

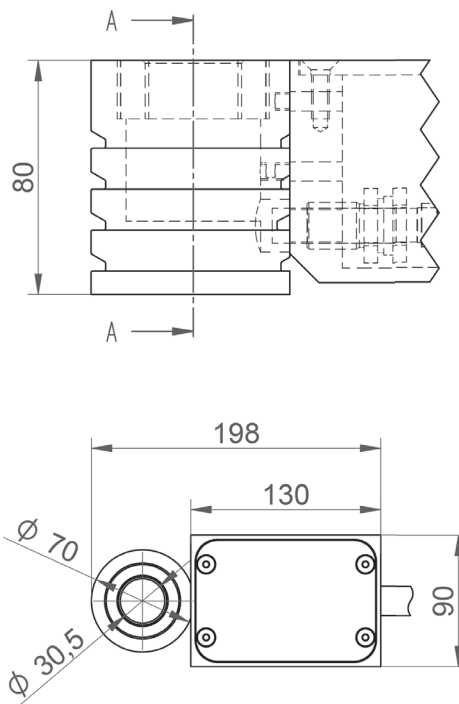

Technical data are subject to changes and errors. Only current article drawings are relevant.