

LOXrail® locking pin

Art. No. 480214 Drawing No. 16002-0760

LOXrail® locking pin for fixation of trolleys in LOXrail® floor sleeve



- Bolt diameter $d=30$ mm
- Hand-/Footlever with indexed position
- Flange plate for mounting to trolley

• Deadweight: 1,7 kg

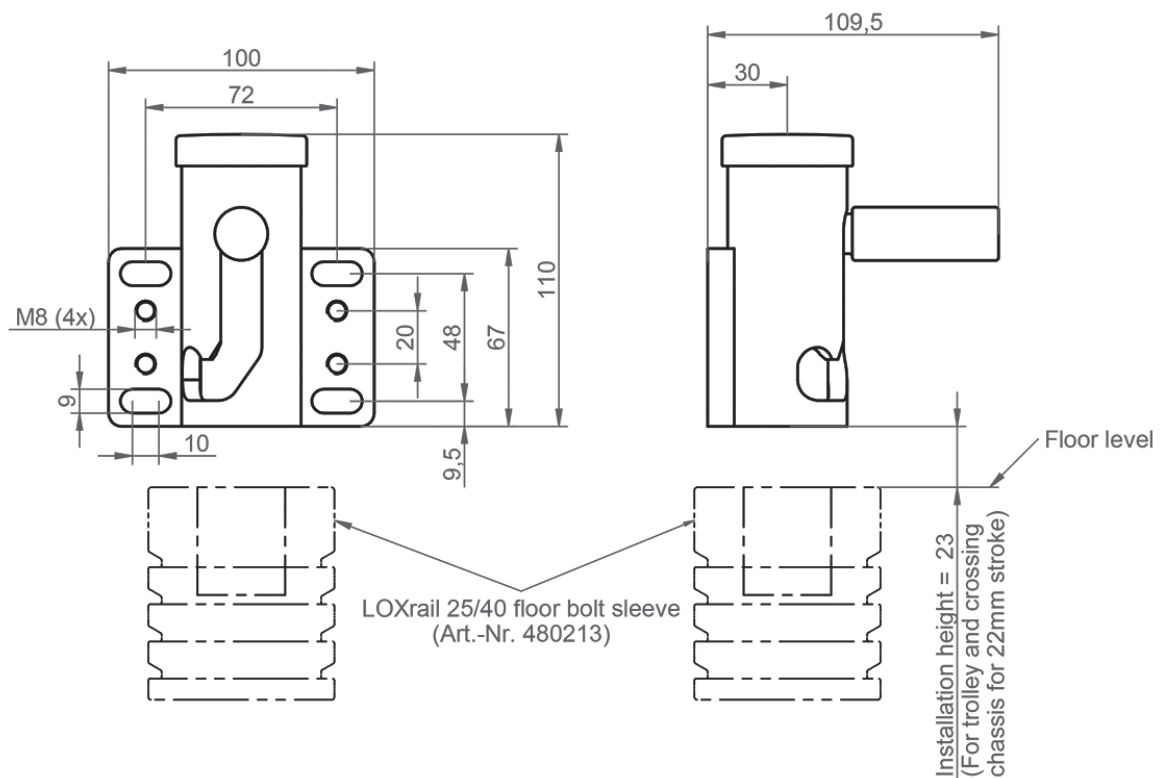

Technical data are subject to changes and errors. Only current article drawings are relevant.