

## LOXrail® wheel set 25-2 MR

Art. No.: 481205      Drawing No.: 16002-0480

### Double wheel set for LOXrail® 25 with additional mounting frame



- **Deadweight:** 6,442 kg
- **Max. Payload:**  
32,8 kN on LOXrail®  
14 kN in case of load on wheel flange

- Easy mounting to existing steel work structures
- Appropriate installation of wheel set to mounting frame
- Easy adjustment to fixed or loose bearing
- Special profile rollers for LOXrail® 25
- Two pc. of brushes wipers to clean the rail
- Defined connecting interfaces enable a precise assembly
- Rubber plate for damping of impacts during the loading of the carrier

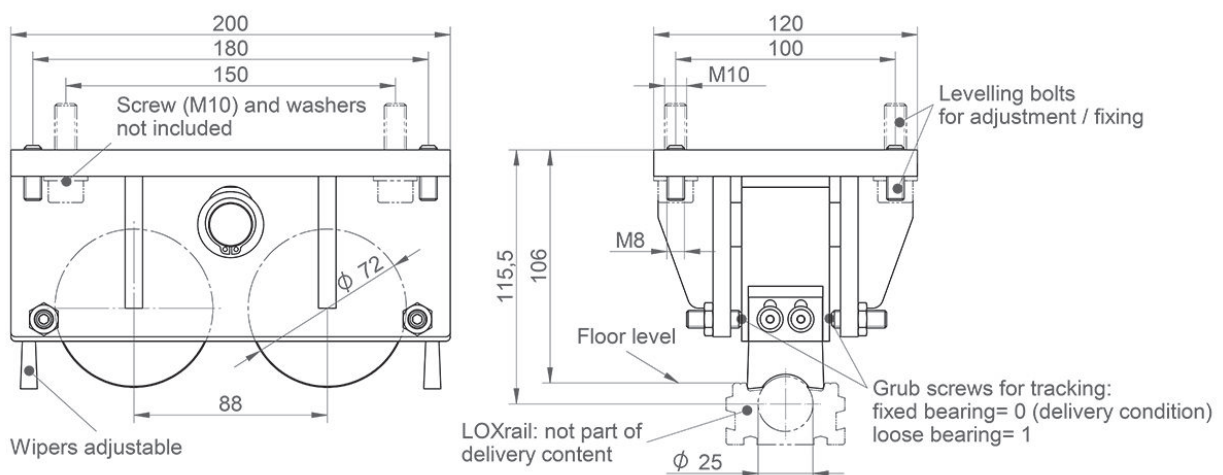

Technical data are subject to changes and errors. Only current article drawings are relevant.