

## LOXrail® idle wheel set 40-2 MR

Art. No. 481207 Drawing No. 16002-0520

### LOXrail® 40 double wheel set for with additional mounting frame



- Easy mounting to existing steel work structures
- Appropriate installation of wheel set to mounting frame
- Easy adjustment to fixed or loose bearing
- Special profile rollers for LOXrail® 40
- Two pc. of brushes wipers to clean the rail
- Defined connecting interfaces enable a precise assembly
- Rubber plate for damping of impacts during the loading of the carrier

• **Deadweight:** 15,945 kg

• **Max. Payload:**

58 kN on LOXrail®

33 kN in case of load on wheel flange

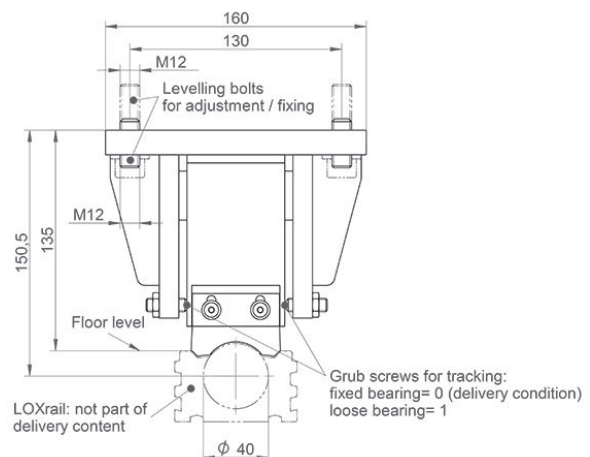
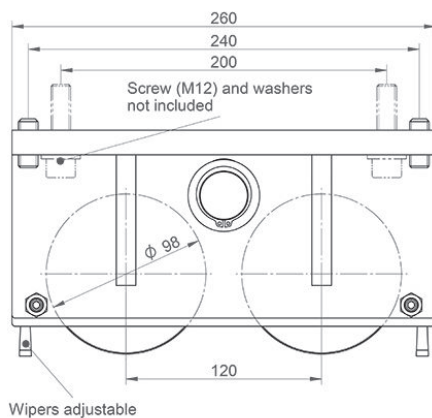

Technical data are subject to changes and errors. Only current article drawings are relevant.