

LOXrail® drive wheel set 40-1 AT

Art. No. 481210 Drawing No. 16002-0445

LOXrail® single wheel set with drive wheel for motorized applications

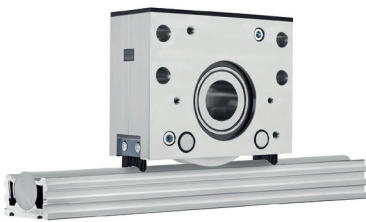

- For use in application with lighter and medium loads
- Drive wheel diameter 160mm
- Special adapters are available for connection to cardan or drive shafts
- Two pc. of brushes wipers to clean the rail
- Defined connecting interfaces enable a precise assembly
- Rubber plate for damping of impacts during the loading of the carrier

• **Deadweight:** 13,198 kg

• **Max. Payload:**

50 kN on LOXrail®

50 kN in case of load on wheel flange

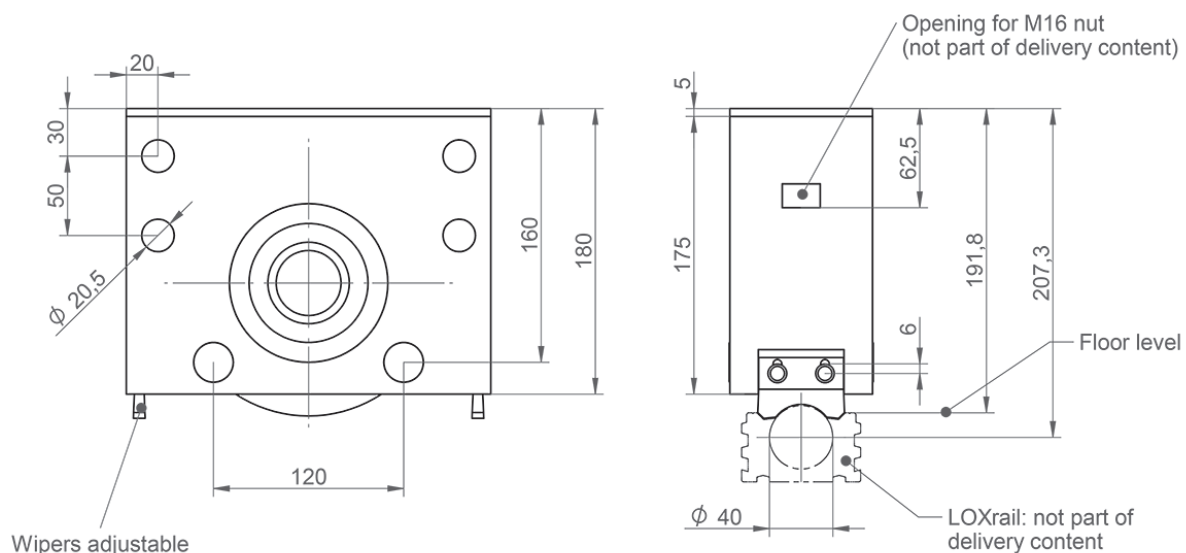

Technical data are subject to changes and errors. Only current article drawings are relevant.