

LOXrail® wheel set 40-2 AT

Art No. 481215

Drawing No. 16002-0440

LOXrail® Double wheel set with drive wheel for motorized applications



- For use in application with medium and high loads
- 2x drive wheel diameter 160mm
- Special adapters are available for connection to cardan or drive shafts
- Two pc. of brushes wipers to clean the rail
- Defined connecting interfaces enable a precise assembly
- Rubber plate for damping of impacts during the loading of the carrier

• **Deadweight:** 20,361 kg

• **Max. Payload:**

100 kN on LOXrail®

100 kN in case of load on wheel flange

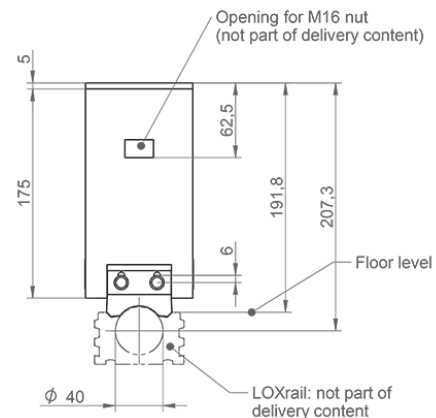
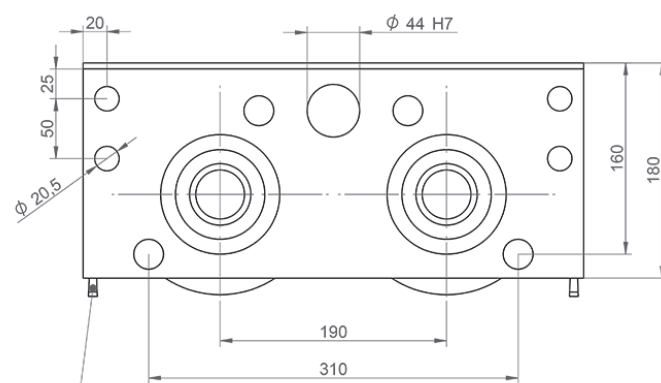

Technical data are subject to changes and errors. Only current article drawings are relevant.