

## LOXrail® wheel set 40-2-260 AT pendulum

Art. No. 481218 Drawing No. 80000-0090

### LOXrail® double wheel set with drive wheel for motorized applications with pendulum connection

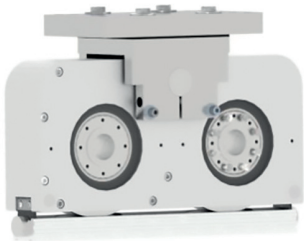

- **Deadweight:** 100,349 kg
- **Max. Payload:**  
150 kN on LOXrail®  
150 kN on cross over elements

- Ensures a symmetrical load sharing between both wheels
- Easy and quick change of wheel set
- For use in application with medium to high loads
- 2x drive wheel diameter 260mm
- Cardan shafts can be mounted directly to the wheels by hole pattern
- Two pc. of brushes wipers to clean the rail
- Defined connecting interfaces enable a precise assembly
- Rubber plate for damping of impacts during the loading of the carrier

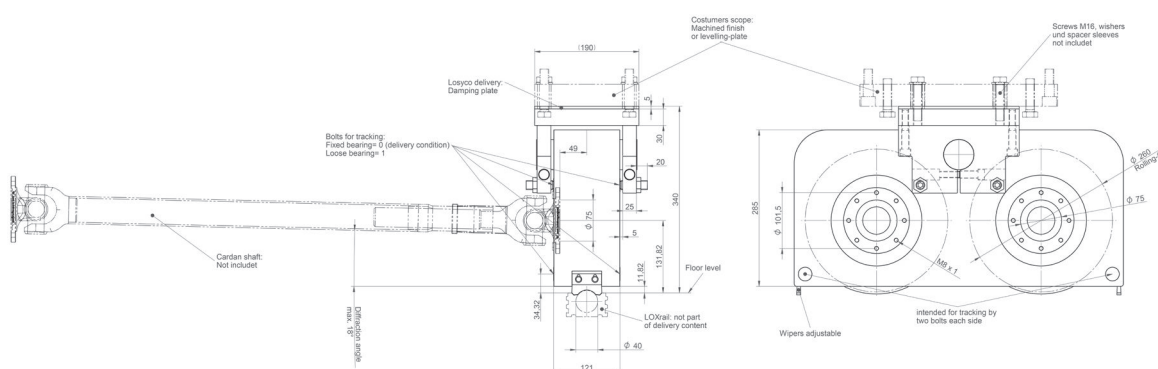

Technical data are subject to changes and errors. Only current article drawings are relevant.