

## LOXrail® drive wheel set 40-2-160 AT pendelum

Art. No. 481219 Drawing No. 80000-0120

### LOXrail® double wheel set with drive wheel for motorized applications with pendulum connection



- Ensures a symmetrical load sharing between both wheels
- Easy and quick change of wheel set
- For use in application with medium to high loads
- 2x drive wheel diameter 160mm
- Special adapters are available for connection to cardan or drive shafts
- Two pc. of brushes wipers to clean the rail
- Defined connecting interfaces enable a precise assembly
- Rubber plate for damping of impacts during the loading of the carrier

• **Deadweight:** 35,018 kg

• **Max. Payload:**

100 kN on LOXrail®

100 kN in case of load on wheel flange

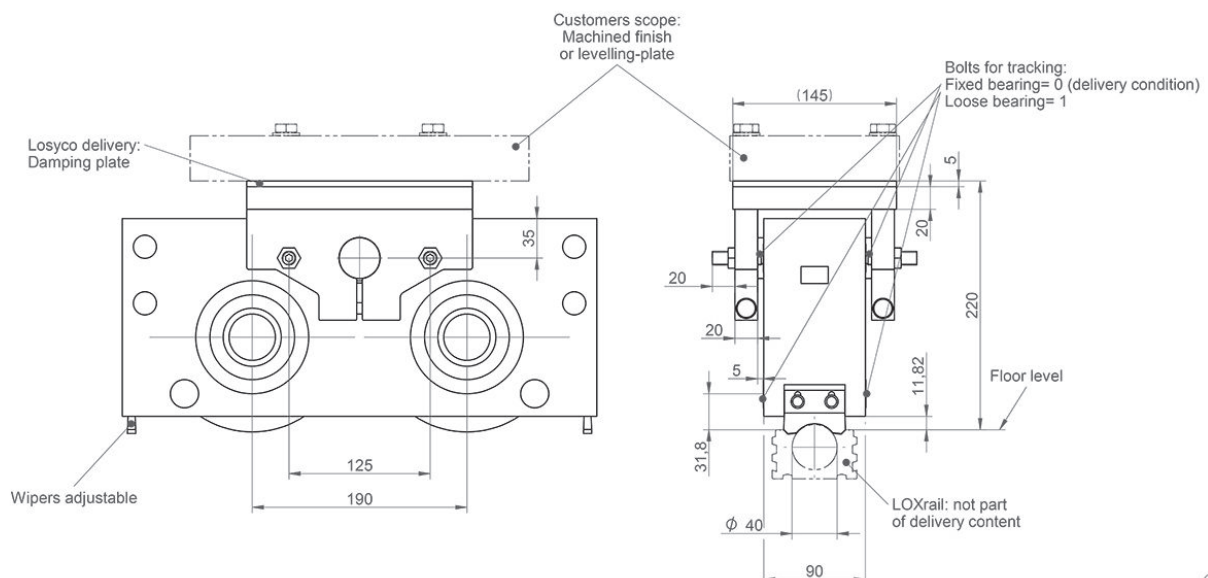

Technical data are subject to changes and errors. Only current article drawings are relevant.