

LOXrail® wheel set 25-2 AT pendulum

Art. No. 481270 Drawing No. 80000-0190

LOXrail® Double wheel set with drive wheels for motorized applications with pendulum suspension



- Ensures a symmetrical load sharing between both wheels
- Easy and quick change of wheel set
- For use in application with medium loads
- 2x drive wheel diameter 160mm
- Special adapters are available for Connection to cardan or drive shafts
- Two pc. of brushes wipers to clean the rail
- Defined connecting interfaces enable a precise assembly
- Rubber plate for damping of impacts during the loading of the carrier

• **Deadweight:** 20,361 kg

• **Max. Payload:**

50 kN on LOXrail®

50 kN in case of load on wheel flange

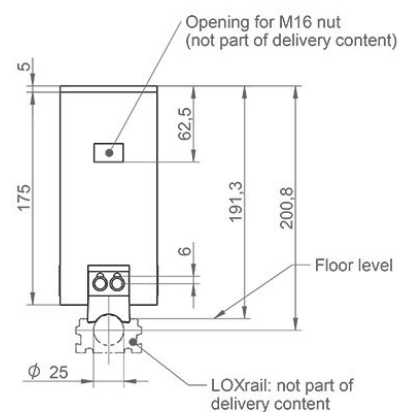
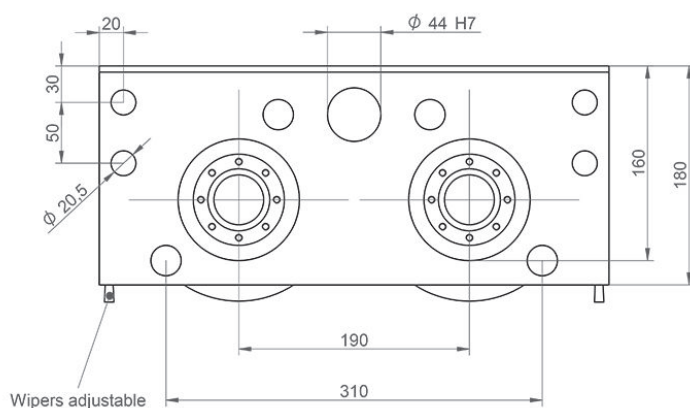

Technical data are subject to changes and errors. Only current article drawings are relevant.