

## LOXrail® Adapter flange set

Art. No. 481301 Drawing No. 16002-0449

### LOXrail® Adapter flange set for drive wheels

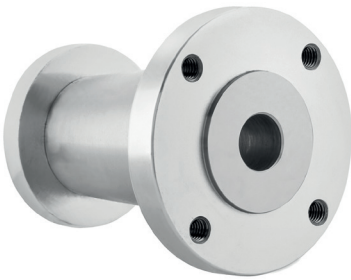

- For connection of cardan shaft to drive wheels
- Including bolt and washer for assembly to drive wheel

• **Deadweight:** 1,863 kg

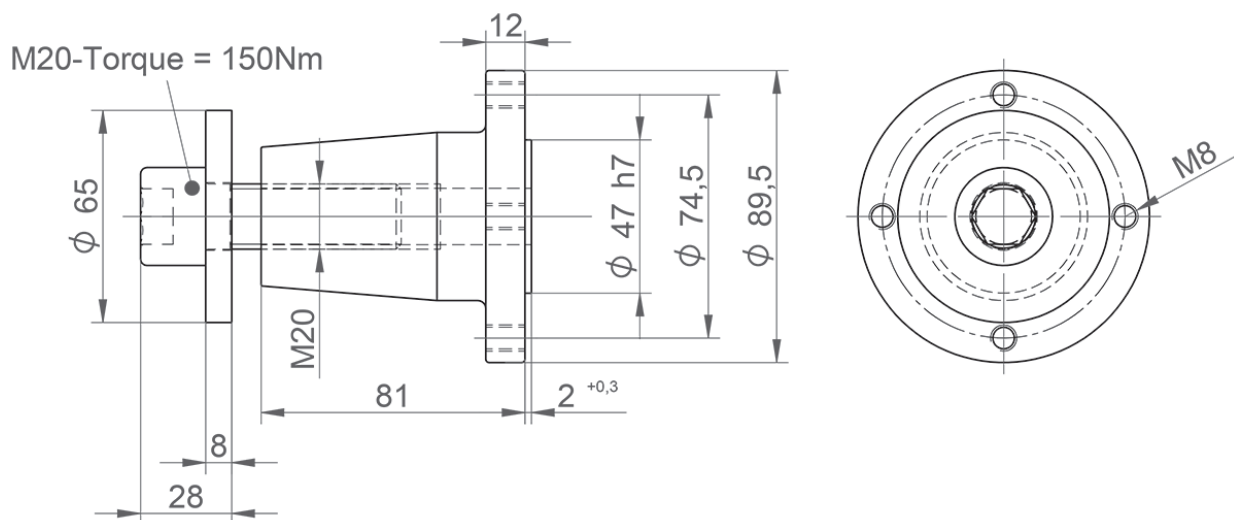

Technical data are subject to changes and errors. Only current article drawings are relevant.